

5MP, TRUE DAY/NIGHT, WDR, IR VANDAL DOME



Varifocal Lens Vandal Dome

IPV5E212MX

- > Fully Adheres to National Defense Authorization Act (NDAA) Guidelines
- > Exceptional Video Quality with 5MP, 2880 x 1620 Resolution
- > Super-Efficient H.265 Video Compression for Drastically Reduced Bandwidth and Storage Requirements
- > Powerful, Smart IR LED Lights for 0Lux Night Time Operation up to 131 Feet
- > 2.8 ~ 12mm motorized varifocal, automatic focus lens
- > TRUE Day/Night and WDR functionality for all Lighting Conditions
- > Built-in microphone, Corridor View, Backlight Compensation, 3D DNR (Digital Noise Reduction)
- > Dual Video Streams, ONVIF Profile Series Compliant
- > Ultra-Motion Detection, Cross Line, Intrusion, Tampering, Audio Detection, and Motion
- > PoE & 12VDC Power Options and Optional Mounts Available
- > Built-in Micro-SD Card Slot enables local storage up to 256GB
- > IP67 Weather Resistant and IK10 Vandal Resistant Rated Vandal Housing
- > Supported by uniview tec Guard Station Software and Guard Viewer Mobile App's for iPhone and Android Devices

Specifications

Camera	
Sensor	1/2.7", progressive scan, 5 megapixel, CMOS
Lens	2.8~12 mm, varifocal automatic focusing and motorized zoom lens
Angle of View (H x V)	108.79° ~ 33.23° x 56.9° ~ 18.33° (Wide ~ Tele)
Shutter	Auto/Manual, 1 ~ 1/100000 s
Minimum Illumination	Color: 0.003 Lux (F1.6, AGC ON); 0 Lux with IR
Day/Night	IR-cut filter with auto switch (ICR)
Digital noise reduction	2D/3D DNR
Signal / Noise Ratio	52dB
IR LED Range	Up to 40m (131 ft) IR range
WDR	120dB
Video Compression	H.265, H.264, MJPEG
H.264 code profile	Baseline profile, Main Profile, High Profile
Maximum Frame Rate / Stream	Main: 5MP (2880 x 1620) @ 25fps Sub: 720P (1280 x 720) @ 30fps
HLC, BLC, 9:16 Corridor, Defog, Flip	Supported
OSD, Privacy Mask, Motion Detection & ROI	Up to 8 areas
Network	
Protocols	IPv4, IGMP, ICMP, ARP, TCP, UDP, DHCP, RTP, RTSP, RTCP, RTMP, DNS, DDNS, NTP, FTP, UPnP, HTTP, HTTPS, SMTP, SSL, QoS, 802.1x, SNMP
Local Edge Storage	Micro-SD, up to 256GB
Network Storage	Automatic Network Replenishment (ANR)
Smart Intrusion Prevention	Ultra Motion Detection, Cross Line, Intrusion, Motion, Audio; Tampering alarm
Compatible Integration	ONVIF (Profile S, Profile T), API
Network	RJ45, 10M/100M Base-TX Ethernet
General	
Power	12VDC +/- 25%, PoE (IEEE802.3 af); Power consumption: Max 7.5W
Dimensions (Ø x H) & Weight	Ø128 x 100mm (Ø5.0 x 3.9"); 0.65kg (1.43lb)
Audio & Compression	Built-in Mic; G.711 Compression
Operating Temperature & Humidity	-30°C ~ +60°C (-22°F ~ 140°F); Humidity: 10%~95% RH (non-condensing)
Conformity Certifications	IP67, IK10; CE, FCC

Dimensions

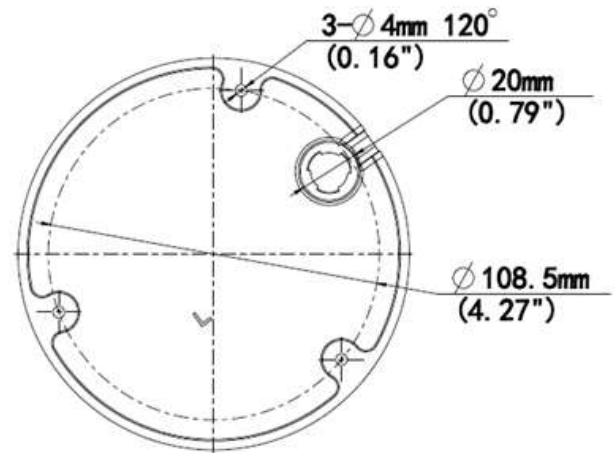
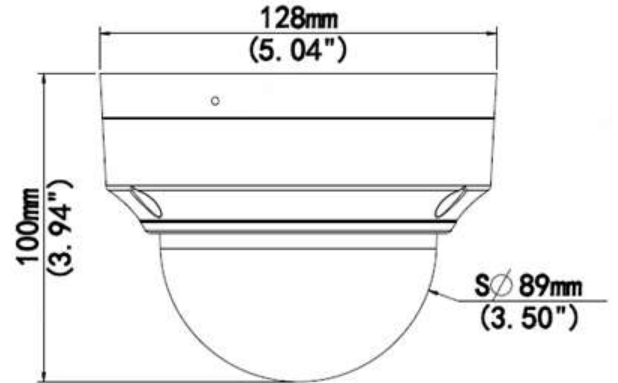

Accessories

See Camera Accessories Guide