

4MP, TRUE DAY/NIGHT, WDR, IR VANDAL DOME



Fixed Lens Vandal Dome

IPV4E28BX

- > Fully Adheres to National Defense Authorization Act (NDAA) Guidelines
- > Exceptional Video Quality with 4MP, 2688 x 1520 Resolution
- > Super-Efficient H.265 Video Compression for Drastically Reduced Bandwidth and Storage Requirements
- > Powerful, Smart IR LED Lights for 0Lux Night Time Operation up to 98 Feet
- > 2.8mm fixed lens
- > TRUE Day/Night and WDR functionality for all Lighting Conditions
- > Corridor Mode, Backlight Compensation and 3D DNR (Digital Noise Reduction)
- > Triple Video Streams and ONVIF Profile S Compliant
- > Ultra Motion Detection, Cross Line, Intrusion, Tampering, and Motion Detection
- > PoE & 12VDC Power Options and Optional Wall and Pendant Mounts Available
- > Built-in Micro-SD Card Slot enables local storage up to 256GB
- > 3-Way Axis, IP67 Weather Resistant and IK10 Vandal Resistant Rated Vandal Housing
- > Supported by uniview tec Guard Station Software and Guard Viewer Mobile App's for iPhone and Android Device

Specifications

Camera	
Sensor	1/3", progressive scan , 4 megapixel, CMOS
Lens	2.8mm @ F1.6
Angle of View (H x V)	101.1° x 55.3°
Shutter	Auto/Manual, 1 ~ 1/100000 s
Minimum Illumination	Color: 0.003 Lux (F1.6, AGC ON); 0 Lux with IR
Day/Night	IR-cut filter with auto switch (ICR)
Digital noise reduction	2D/3D DNR
IR LED Range & Wavelength	Up to 30m (98 ft) IR range; 850nm
WDR	120dB
Video Compression	H.265, H.264, MJPEG
H.264 code profile	Baseline profile, Main Profile, High Profile
Maximum Frame Rate / Stream	Main: 4MP (2688 x 1520) @ 25fps, 4MP (2560x1440) @ 25fps, 3MP (2305x1296) @ 30fps, 2MP (1920x1080) @ 30fps Sub: 720P (1280 x 720) @ 30fps, D1 (720x576) @ 30fps, 640x360 @ 30fps
HLC, BLC, 9:16 Corridor Mode, Defog, Flip	Supported
OSD, Privacy Mask, Motion Detection & ROI	Up to 8 areas
Network	
Protocols	IPv4, IGMP, ICMP, ARP, TCP, UDP, DHCP, RTP, RTSP, RTCP, RTMP, DNS, DDNS, NTP, FTP, UPnP, HTTP, HTTPS, SMTP, SSL, 802.1x, SNMP
Compatible Integration	ONVIF (Profile S, G, T), API
Network	RJ45, 10M/100M Base-TX Ethernet
Intrusion Detection Analytics	Ultra Motion Detection, Cross-Line, Intrusion, Motion Detection, Tampering Alarm
Local Storage	Micro-SD, up to 256GB
Network Storage	Automatic Network Replenishment (ANR)
General	
Power	12VDC +/-25%, PoE (IEEE802.3 af); Power consumption: Max 5.5W
Dimensions (Ø x H) & Weight	Ø109 x 81 mm (Ø4.3" x 3.2"); 0.35kg (0.77lb)
3-Axis Adjustment Range	Pan: 3° ~ 360° Tilt: 0° ~ 68° Rotate: 3° ~ 360°
Operating Temperature & Humidity	-30°C ~ +60°C (-31°F ~ 140°F); Humidity: 10%~ 95% RH (non-condensing)
Conformity Certifications	IP67, IK10; CE, FCC

Dimensions

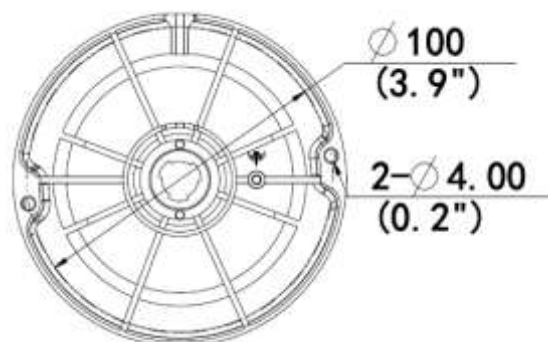
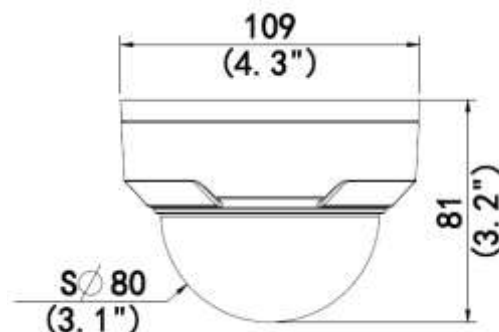

Accessories

See Camera Accessories Guide